

# TMS9928/29 and TMS9128/29

Interface to Color Monitors

Annotated by Nicholas Piegdon

2020-08-01  
v1

Video Display Products  
Application Report



## INTRODUCTION

This application report describes a circuit which will take the R-Y, B-Y, and Y output signals from the TI TMS9928/29 or TMS9128/29 and convert them to signals suitable for driving most composite video input or R-G-B and composite sync input color monitors. Although the circuits used to create these outputs are completely different, they are all covered in this application report since all require dc restoration and sync separator circuitry. R-G-B drive is recommended for anyone who has a requirement for very high quality color display, since this method of interface will produce a much sharper display than that which can be achieved via a composite video interface. The circuit is easily modified to provide correct drive to a wide variety of color monitors.

For ease of discussion, the circuit has been divided into six sections:

- 1) Dc Restoration
- 2) Sync Separator
- 3) R-G-B Converter
- 4) Synchronous 3.58 MHz Generator
- 5) PAL Encoder
- 6) Composite Video Encoder

This approach also allows the user to incorporate only those sections required for his particular application into his design. For prototyping purposes, the circuit described here and shown in Figure 1 is available on a printed circuit board from the Texas Instruments Chicago Regional Technology Center.

## DC RESTORATION

Dc restoration of the analog output signals from the TI video display processors is required in this instance to shift the blanking level of the outputs to 0 Vdc. This cannot be done with a dc biasing scheme because the output level of the video display processor can vary from device to device as a function of process, or as a function of temperature. Capacitor coupling will not prove satisfactory because this would shift the average dc value of the video signal to the bias point. This would present a problem to the color subcarrier modulator in the composite video encoder. In the case of the R-G-B encoder, a black screen with dark red letters might appear as a gray screen with pink letters without dc restoration.

Dc restoration of the Y signal is accomplished via clamping diode CR2, which will force the most negative voltage at its cathode to one diode drop below the bias voltage set at the anode. Since the most negative voltage on the Y channel is the sync pulse, it is this pulse which forward biases the diode and clamps the sync pulse to one diode drop below the bias point. The bias voltage at the anode is adjusted to set the blanking level to 0 Vdc. Unfortunately, the R-Y and

B-Y signals are not guaranteed to have a most negative or positive excursion within any particular period of time, so diode clamping will not work with these signals. Dc restoration of the R-Y and B-Y signals is accomplished by turning on analog transmission gates U4A and U4B during the sync interval, and thereby clamping the voltage on the negative side of capacitors C14 and C16 to ground during this interval. Since the R-Y and B-Y signals are at the same potential during sync as they are during blanking (with the exception of the color burst interval), this accomplishes dc restoration of these signals.

## SYNC SEPARATOR

A sync separator is created in a manner similar to the manner dc restoration is accomplished on the Y signal. In this case, the negative going sync signal forward biases transistor Q2, creating a positive going sync signal at its collector. This is inverted by Q3, whose collector provides feedback to the base of Q2 to ensure clean transitions, as well as providing negative going composite sync for a R-G-B monitor. The value of resistor R29 is selected to provide 1 volt of sync into a  $75\Omega$  input impedance. The value of resistors R29 and R32 may be changed to interface to other inputs.

## R-G-B CONVERTER

The R-G-B converter operates by adding Y to the R-Y and B-Y signals via LM318 operational amplifiers to produce the red and blue drives to the R-G-B monitor. It should be noted that, in conformance to standard industry practice, the R-Y output of the video display processors has been divided by a factor of 1.14, and the B-Y by a factor of 2.03. This was done to prevent overmodulation when the chroma subcarrier was added to the luminance signal. In this application it is not critical to correct the R-Y signal, since the error is rather small. Compensation must be made for the B-Y signal, or severe color distortion will result. Since the purpose of this circuit is to produce a bright, sharp image from the TMS9928 rather than to produce a very accurate color difference to the R-G-B converter, the components in this circuit have been selected to make the colors of bright red, green, blue, cyan, magenta, and yellow as close to fully saturated as possible. Variable resistors R52, R53, and R54 have been included in the circuit in order to accommodate monitors requiring more (or less) than one volt peak-to-peak of drive, or to allow colors to be adjusted to suit a particular application.

Red drive is provided by operational amplifier U7. R-Y and Y are added via R35 and R36 to produce R/2. A gain of two can be obtained by setting R52 to 4 k $\Omega$ . This will provide 1 volt (max) of red drive.

Gain of two.  
 $1 + 5k/5k = 2$

Same components as the red channel.



With a gain of three, the blue output becomes:

$$B \approx Y + 2(B-Y)$$

Both Light Blue and Dark Blue will exceed 1.4V.

R54.

Blue drive is provided by operational amplifier U8. R38 is one-half the value of R37, so the B-Y signal is weighted by a factor of two. This generates B/3 at the plus input of U8. If R53 is set to 4 kΩ, U8 will have a gain of three, and therefore produce 1 volt (max) of blue drive.

Green drive is generated via U9, which must satisfy the equation:

$$G = \frac{Y - (.3R + .11B)}{.59}$$

It is derived from the NTSC equation  $Y = .3R + .11B + .59G$ . When R55 is set to 4 kΩ, 1 volt of green drive will be produced.

Since the luminance signal (Y) contains composite sync; R, G, and B each contain a negative sync pulse. If this is undesirable, diode CR1 and resistor R34 may be added, which will eliminate the sync pulse from the R-G-B outputs.

### SYNCHRONOUS 3.58 MHz GENERATOR

A chroma subcarrier which is related to the horizontal line rate is highly desirable, since this will minimize the effect of interference patterns caused by the chroma subcarrier falling within the bandwidth of the luminance signal. This is no problem on the TMS9128, which has a 3.58 MHz output. On the TMS9928, the multiply-by-eight circuit shown here can be used to produce a 3.58 MHz signal from the 447 kHz GROM CLK signal, or an asynchronous 4.43 MHz signal for a PAL interface from the TMS9929 or TMS9129.

For synchronous 3.58 MHz, GROM CLK is applied to U1, a NE564 phase locked loop. The output of the PLL is fed into a divide-by-8 circuit formed with U2A, U2B, and U3A. The 447 kHz output from the divide-by-8 circuit is then fed back to the PLL.

For PAL operation, the divide-by-8 circuit is bypassed, and oscillator capacitor C2 is replaced with a 4.43 MHz crystal. The GROM CLK input must be tied to ground. It should be noted that there are far more cost effective ways of implementing a 4.43 MHz oscillator. This method is recommended only if the circuit must be convertible to NTSC composite video.

## PAL ENCODER

A simple circuit for generating composite video for the European PAL standard is implemented by taking the 4.43 MHz output from the PLL, and producing a 180° phase shift through transistor Q1. The inverted waveform is then applied to U4C, while the non-inverted 4.43 MHz waveform is applied to U4D. These transmission gates are then enabled on alternate horizontal lines by flip-flop U3B, which is toggled by the horizontal sync pulse from the collector of Q3. Level shifting from the TTL output of U3 to the -5 V to +5 V swing required at the gate input of U4 is accomplished by transistors Q4 and Q5. The output of both analog transmission gates is then fed to the chroma subcarrier input on the composite video encoder.

### COMPOSITE VIDEO ENCODER

Both NTSC and PAL composite video are generated by this circuit. U5, a LM1889 modulator, forms the chroma modulator which accepts the dc restored R-Y and B-Y signals from the video display processor, and generates a phase modulated chroma subcarrier output. This subcarrier is supplied to the video adder and output driver, U6. Y, the luminance and sync output of the video display processor, is supplied to U6 through the 3.58 MHz trap formed by L2, C24, and R12. This trap removes any of the harmonic content of the Y signal which might fall within the range of the chroma bandpass filter in the monitor, and therefore minimizes the "rainbow" effect which this can cause.

### R-G-B BOARD SETUP OPTIONS

The R-G-B setup options for the circuit just described are listed in Table 1. The various functions available (RGB only, RGB-NTSC, or RGB PAL) may be selected by the positions of jumpers W1 through W7 and the inclusion/exclusion of R34. The number 9928 or 9128 in a column indicates that the jumper shown should be in place if that device is being used; otherwise, the jumper should be out.

Table 1. R-G-B Board Setup Options

Function	Jumpers/Resistor Configurations							
	W1	W2	W3	W4	W5	W6	W7	R34
RGBY Only	9128	9928	9928	9128	Out	Out	Out	8.2 kΩ
RGB-NTSC	9128	9928	9928	9128	In	Out	In	Out
RGB-PAL*	Out	In	Out	In	Out	In	In	Out

\*When generating PAL on PALN video, C2 should be replaced with a crystal of the desired chroma subcarrier frequency, and C6 should be changed to tune the combination of L1 (47 μH) and C6 to that frequency.

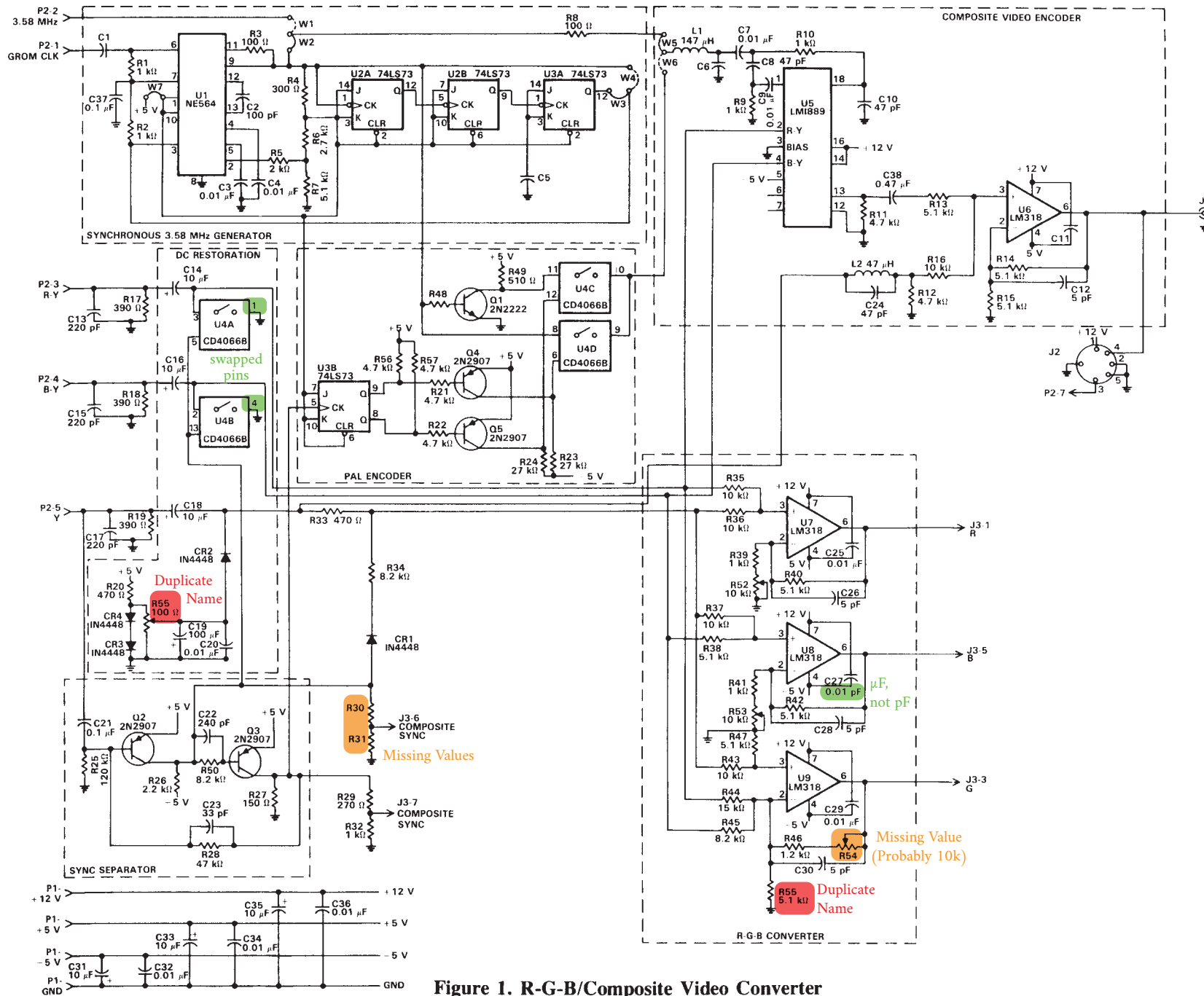

Figure 1. R-G-B/Composite Video Converter

## CONCLUSION

A R-G-B/Composite Video Converter that can be used to interface a TMS9928/29 or TMS9128/29 to various color monitors has been described in this application report. The system presented converts R-Y, B-Y, and Y signals to either analog R-G-B and composite sync, or composite video signals as required by different color monitors. The composite video signal can also be used as input to a RF modulator for interface to a standard television set. In

general, if the application will allow it, R-G-B interface is strongly recommended. This will allow an image far superior to that which can be obtained via a composite video interface, since it is free of the bandwidth restrictions inherent in the NTSC system. Additionally, low and medium resolution monitors can often be purchased more cheaply than their composite video counterparts. Each of the six sections used were identified and described so that the user might incorporate only those sections required for a specific application into his design.

# APPENDIX A

## EVM-RGBCNV-01 Features and Specifications

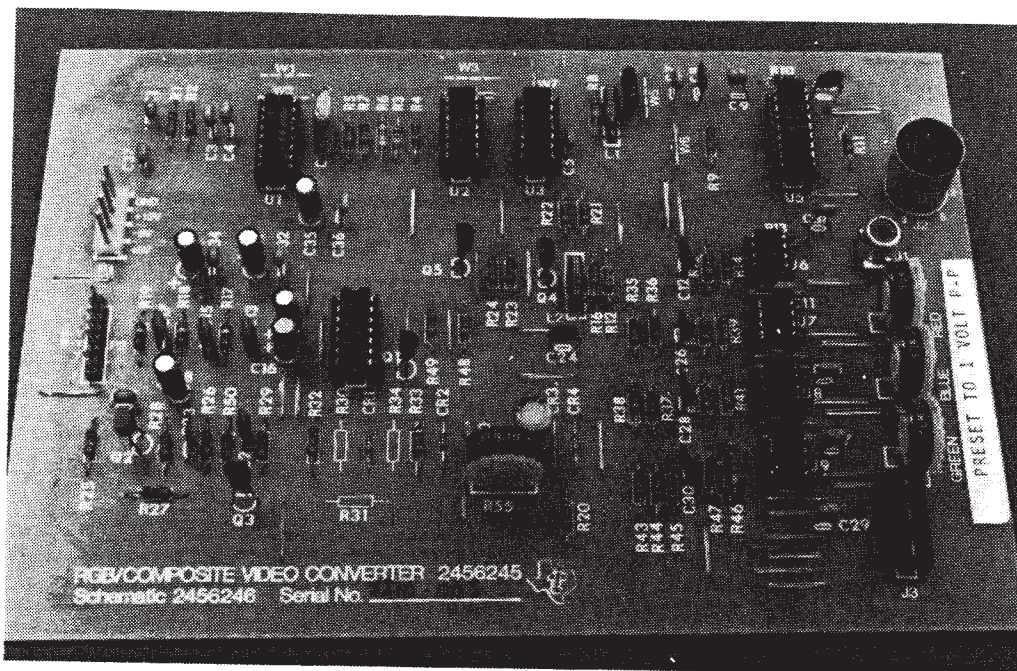

Figure A-1. EVM-RGBCNV-01 R-G-B/Composite Video Converter

The EVM-RGBCNV-01 can be used to interface a TMS9928/29 or TMS9128/29 to various color monitors. The board is generally intended for use as a prototype that demonstrates the essential sections required for either a R-G-B or composite video converter.

### FEATURES

- Converts R-Y, B-Y and Y outputs to:
  - Composite Video (NTSC for TMS9928 and PAL for TMS9929)
  - R-G-B signals for use with high-resolution monitors
- Excellent board for prototyping
- Low power consumption
- Adjustable R-G-B gain

### SPECIFICATIONS

Power Requirements (Typical):  
+12 V at 50 mA  
+5 V at 30 mA  
-5 V at 30 mA

Operating Temperature: 0°C to 70°C

Board Dimensions: Width 143 mm (5 5/8 inches)  
Height 206 mm (8 1/8 inches)

For additional information, contact your nearest TI Field Sales Office, or:

Texas Instruments Incorporated  
Chicago Regional Technology Center  
515 W. Algonquin Road  
Arlington Heights, Illinois 60005  
(312) 640-2909 (RTC)